



**ZANOTTI Spa**

Via M.L. King, 30  
46020 - Pegognaga (MN) - ITALY  
Tel. +39 0376 5551  
Fax +39 0376 536554  
info@zanotti.com

# Technical specifications

Version 2.2

Model:

Class:

**BGM117DC11XA71**

**Uniblock GM**

## Technical data

Characteristics	M.U.	Value
Working temperature	°C	-15 / -25
Starting mode		Direct
Voltage	Volt-Ph-Hz	220/1/60
Rated input	kW*	0,92
Rated input	Amp*	4,20
LRA	Amp	38.7
Run Amp	Amp	4.6
Refrigerant		R452A
	GWP	2140
Defrost		Hot gas
Mass	Kg	64

## Compressor

Type	Hermetic	
Nominal power	HP	1¾

## Condenser

Air flow	m³/h	600
----------	------	-----

## Evaporator

Air flow	m³/h	600
Air throw	m**	4

PED Category	0
--------------	---



## Power data

Tc °C	Ta °C	P watt	P Kcal/h	V120 m³	V100 m³	V80 m³
	20	1513	1301	13	12	10
	25	1429	1229	12	11	9,4
-15	30	1341	1153	10	8,9	7,8
	35	1251	1076	9,2	8,2	7,2
	40	1158	996	8,1	7,2	6,3
	45	1066	917	7,1	6,3	5,5
	20	1297	1115	9,8	8,7	7,6
	25	1224	1053	8,9	7,9	6,9
-20	30	1155	993	8,1	7,2	6,3
	35	1081	930	7,2	6,4	5,6
	40	993	854	6,3	5,6	4,9
	45	881	758	5,1	4,5	4
	20	1090	937	7,3	6,5	5,7
	25	1016	874	6,5	5,8	5,1
-25	30	943	811	5,7	5,1	4,4
	35	871	749	5	4,4	3,9
	40	798	686	4,3	3,8	3,4
	45	725	624	3,6	3,2	2,8

\* When normally running: -20 / +30°C

\*\* Use air throw as a base. Air throw is affected by many factors such as height of room, product storage, location of evaporator, etc.

Tc: Coldroom temp. - Ta: External temp.

P: Refrigerant capacity - V: Recommended cold-room volume

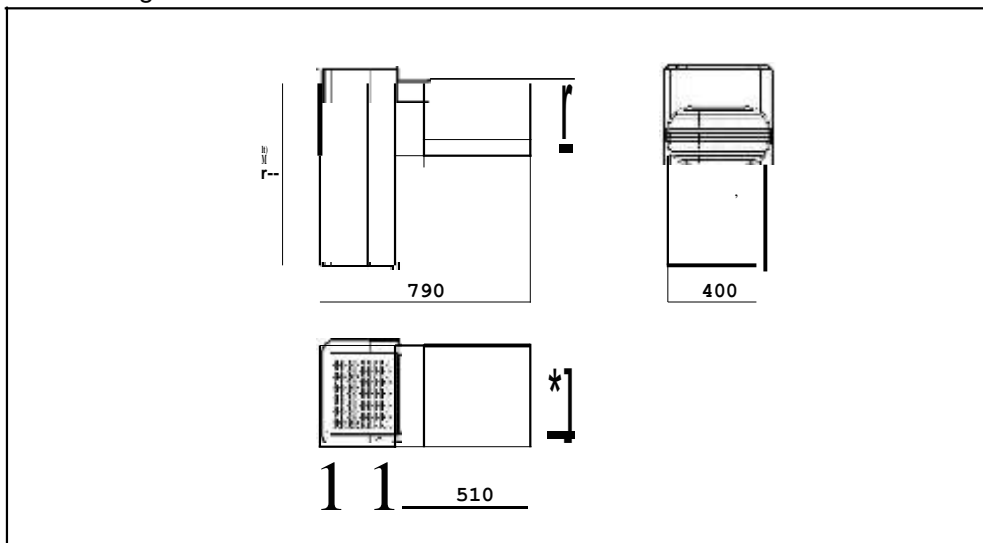

Schema di montaggio - Mounting scheme - Schema de montage  
Montageschema - Esquema de montaje

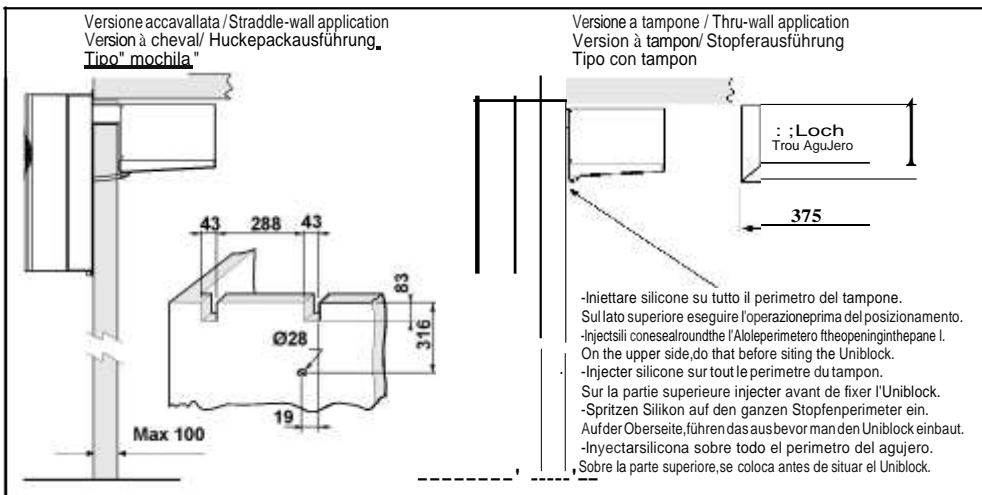

\*Raccomandazioni in sede di installazione e per il controllo fornite sui manuale di installazione

\* To be advised at time of order for factory installation and operating instructions

\* Recommendations au moments d'installations et pour le contrôle fournis sur le manuel d'installation

\* Empfehlungen für die Installationsphase und zur Kontrolle, die im Handbuch zur Installation enthalten sind

\* Por cuanto respecta a recomendaciones de instalacièn y contraí ver manual de instalacièn

Massa e misure imballi - Packing mass and dimensions - Masse et dimensions emballages  
Verpackungsmasse und-abmessungen - Masa y medidas del embalaje

